



- Ⓘ **Gamma ERPICI ROTANTI**
- Ⓖ **POWER HARROWS Range**
- Ⓕ **Gamme HERSES ROTATIVES**



(GB) For many years now power harrows have been the most versatile implements for soil cultivation, thank to the fact that they adapt to any type of soil and situation. Moreover, the possibility of combining them to seed-drills offers a profitable solution for seed-drill operation as well.

(IT) Gli erpici rotanti sono da anni le macchine professionali più flessibili per la lavorazione del terreno grazie al loro adattamento su tutti i tipi di terreno e situazioni. Inoltre la loro possibilità di essere combinate con una seminatrice permette una soluzione vantaggiosa anche nella semina.



RA
25 - 70 HP

Pg. 14



BD
50 - 100 HP

Pg. 15



BE
65 - 120 HP

Pg. 16



BF
65 - 140 HP

Pg. 17



DJ
90 - 180 HP

Pg. 22-23



DJ SUPER

110 - 220 HP

Pg. 22-23

ERPICI ROTANTI FISSI E PIEGHEVOLI
RIGID AND FOLDABLE POWER HARROWS
HERSES ROTATIVES FIXES ET REPLIABLES

Gamma / Range / Gamme

FR

Les herse rotatives sont depuis longtemps les machines les plus polyvalentes pour le travail du sol grâce à leur adaptation à tous les types de terres et de conditions. Les herse rotatives Alpego sont le fruit d'une longue expérience dans le travail du sol et constitue l'aboutissement de longues années de recherche pour vous offrir la performance et la fiabilité que vous recherchez.



RM
RM SUPER

80 - 170 HP

Pg. 18



RK

90 - 200 HP

Pg. 19



Rmax

120 - 320 HP

Pg. 20



Dmax

180 - 500 HP

Pg. 28



DKS

130 - 300 HP

Pg. 26



DP

120 - 270 HP

Pg. 24

Componenti realizzati con acciaio **SSAB** autoresistenziale.

Manufactured with **SSAB** high tensile steel.

Pièces réalisées avec de l'acier **SSAB** à très haute limite d'élasticité.



PERCHÈ L'ERPICE ALPEGO WHY AN ALPEGO POWER HARROW PORQUOI UNE HERSE ROTATIVE ALPEGO

Protezione rotori / Rotor guard / Protections des rotors

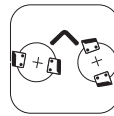

Le protezioni anteriori evitano ai sassi di entrare e danneggiare i rotori.

The front guards prevent rocks from entering to cause rotor damage.

Les protections avant évitent aux cailloux d'entrer et de détériorer les rotors.

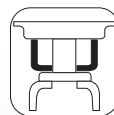

Le semiprotezioni, oltre a proteggere i rotori dall'usura, migliorano l'affinamento e la qualità di lavoro del terreno.

Not only do the half guards protect the rotors from wearing off, they also improve the crumbling effect and the work quality of the soil.

Les demi-protections, en plus de protéger les rotors contre l'usure, permettent un meilleur affinement et une qualité de travail du sol optimale.



Tutti i supporti dei coltelli montati su gli erpici di nostra produzione seguono una precisa sequenza, questa evita vibrazioni agli organi di trasmissione con una conseguente riduzione di potenza consumata.

All the tines supports assembled on our power harrows follow an exact sequence; that prevents vibrations on the transmission system and consequently allows for a decreased power consumption.

Tous les portes dents des herse rotatives Alpego suivent un déphasage précis permettant de garantir l'absence de vibration et de réduire au maximum la puissance absorbée au travail.

**ERPICI ROTANTI FISSI E PIEGHEVOLI
RIGID AND FOLDABLE POWER HARROWS
HERSES ROTATIVES FIXES ET REPLIABLES**

Controllo della profondità di lavoro / Control of working depth / Contrôle de la profondeur de travail



La barra di affinamento degli erpici Alpego viene montata direttamente sul rullo. Questo permette di mantenere costante l'altezza dal suolo, migliorando la qualità del livellamento e riducendo la potenza assorbita.

The leveling bar of the ALPEGO power harrows is directly attached to the rear roller. This makes it possible to maintain a constant height from the ground, thereby improving the leveling quality and reducing the power absorbed by the power harrow.

La barre niveleuse des herse Alpego est montée directement sur le rouleau. Cela permet de maintenir une hauteur de travail constante, et améliore la qualité d'affinement et réduit la puissance demandée.



STANDARD

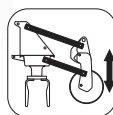

PARALLELOGRAMMA

Con il sistema di regolazione della profondità a PARALLELOGRAMMA il rullo mantiene sempre la stessa inclinazione, quindi:

- la barra di affinamento sempre registrata;
- nelle combinazioni con seminatrice elementi di semina a pressione costante.

Thanks to the PARALLELOGRAM system of depth adjustment, the rear roller constantly maintains the same degree of inclination, therefore:

- *The leveling bar is constantly correctly adjusted;*
- *In the combination with a seed-drill the pressure of the seeding coulters is kept constant*

Avec le système de réglage de profondeur monté sur parallélogramme, le rouleau garde toujours la même inclinaison, ainsi:

- la barre niveleuse garde la même position
- en combinaison avec un semoir, les éléments semeurs conservent leurs réglages identiques.

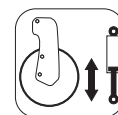

Correttore idraulico di profondità
Hydraulic depth adjustment

Correcteur hydraulique de profondeur

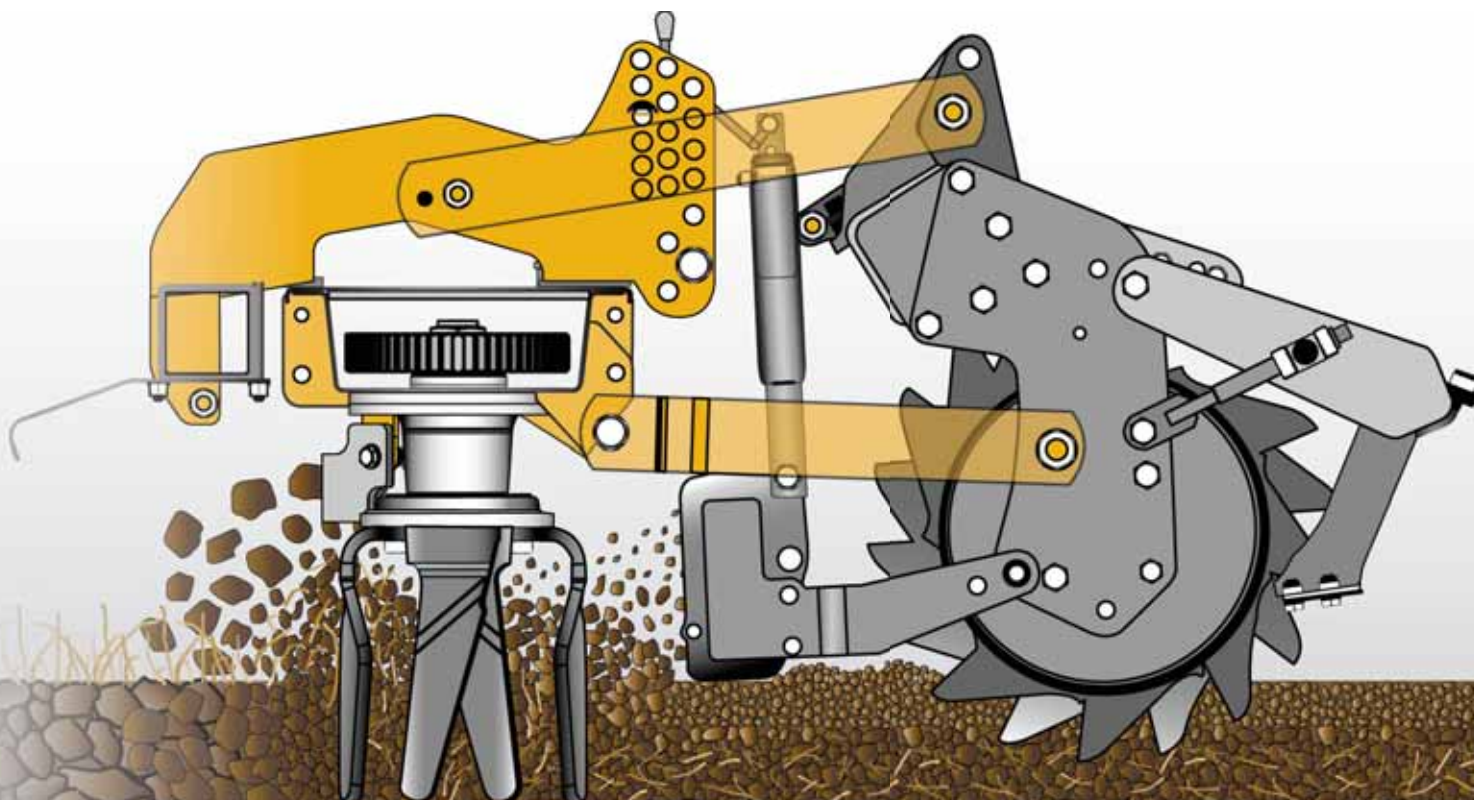



(FR) Les herse rotatives fixes et repliables combinées avec les semoirs mécaniques ou pneumatiques ALPEGO, deviennent l'outil idéal pour vous permettre de réduire vos coûts et vos temps de travaux.

(GB) Both folding and rigid power harrows combined with the mechanical or pneumatic ALPEGO seed-drills become the ideal tool geared toward a reduction of costs and of the working times.

(IT) Gli erpici fissi e pieghevoli, combinati con le seminatrici meccaniche e pneumatiche ALPEGO, diventano lo strumento ideale per la riduzione dei costi e dei tempi di utilizzo.



Airspeed AS1



Combinabile con erpici Fissi /
Can be mounted on rigid power harrows /
Combinable avec herse fixe

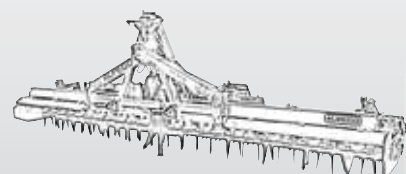

Combinabile con erpici Pieghevoli /
Can be mounted on folding power harrows /
Combinable avec herse repliable



FERTIDRILL ASF



FERTIDRILL AsmaX



Airspeed AS4
POWER

Nuovi denti Forgiati / New Drop-Forged tines / Nouvelles dents Forgées



I NUOVI DENTI FORGIATI SONO:

Disponibile nella versione "Forgiata Rapida" per i modelli RK, DK, RmaX e DmaX e "Forgiata con fissaggio a bullone" per i modelli RmaX e DmaX.

THE NEW DROPFORGED TINES ARE:

Available in the new version "Drop Forged Quick Fit" for models RK, DK, RmaX and DmaX and in the "Drop Forged Bolt-on" version for the models RmaX and DmaX.

LES NOUVELLES DENTS FORGÉES SONT:

Disponibles en version "Forgée Rapide" pour les modèles RK, DK, RmaX et DmaX et "Forgée avec fixation à boulons" pour les modèles RmaX et DmaX.

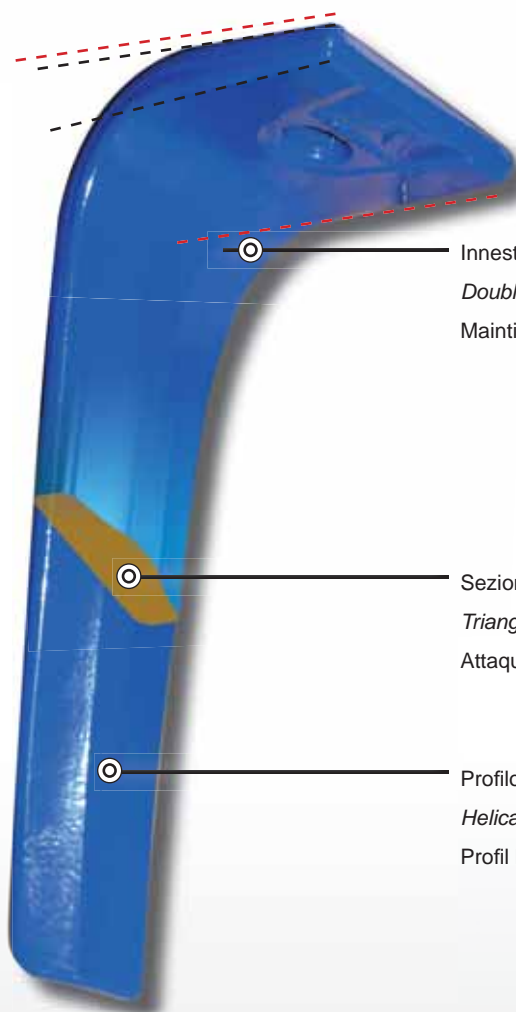

Innesto doppio conico
 Double conical joint
 Maintien double conique

Sezione triangolare
 Triangular section
 Attaque triangulaire

Profilo elicoidale
 Helical contour
 Profil hélicoïdal

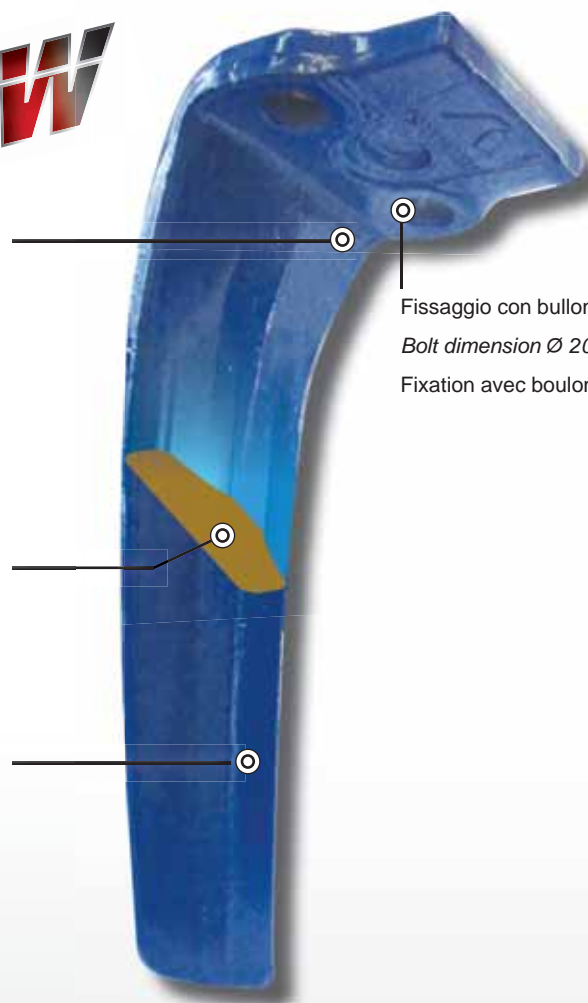

Fissaggio con bullone Ø 20 mm
 Bolt dimension Ø 20 mm
 Fixation avec boulons Ø 20 mm

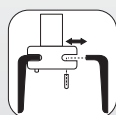

KIT SMONTAGGIO RAPIDO DENTE FORGIATO

Il sistema RAPIDO può essere fornito separatamente in Kit come alternativa al sistema tradizionale.

KIT FOR THE QUICK RELEASE OF THE FORGED TINE

The QUICK-RELEASE system can also be supplied as a separate kit as an alternative to the traditional one.

KIT DE DÉMONTAGE RAPIDE DENT FORGÉE

Le système rapide peut être fourni séparément en kit en alternative au système traditionnel.





TRASMETTIAMO POTENZA WE TRANSMIT POWER TRANSMISSION DE LA PUISSANCE

NEW

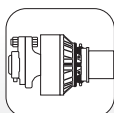

CARDANI CON LIMITATORE A BULLONE
UNIVERSAL JOINT WITH SHEAR BOLT SAFETY SYSTEM
CARDAN À SÉCURITÉ BOULON

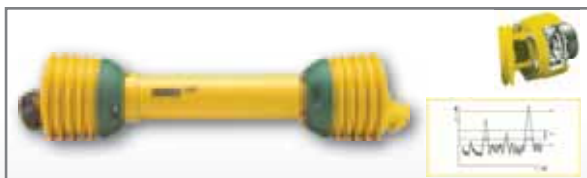

CARDANO CON LIMITATORE AUTOMATICO
Nelle condizioni più difficili il cardano con limitatore automatico WALTERSCHEID rappresenta la soluzione più affidabile e professionale.
UNIVERSAL JOINT WITH AUTOMATIC CAM CLUTCH SAFETY SYSTEM
When working conditions are very severe, the WALTERSCHEID universal joint with automatic cam clutch is the most reliable and professional solution.

CARDAN À SÉCURITÉ AUTOMATIQUE À CAMES
Dans les conditions les plus difficiles, le cardan à sécurité automatique à cames WALTERSCHEID est la solution la plus efficace et la plus fiable.

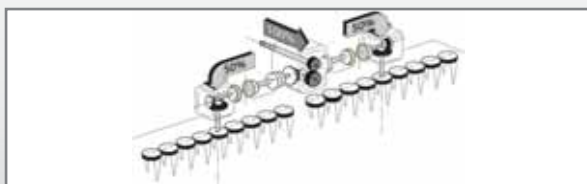
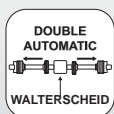

SISTEMA DI SICUREZZA CON DUE CARDANI AUTOMATICI
Permette una immediata messa in sicurezza delle due trasmissioni laterali in maniera indipendente.
TWIN AUTOMATIC DRIVE SHAFTS SAFETY SYSTEM
Lateral gear boxes are independently protected by the safety system in each lateral drive shaft.

SYSTEME DE SECURITE AVEC DEUX CARDANS AUTOMATIQUES
Permet une mise en sécurité immédiate des deux transmissions latérales de manière indépendante.

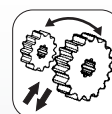
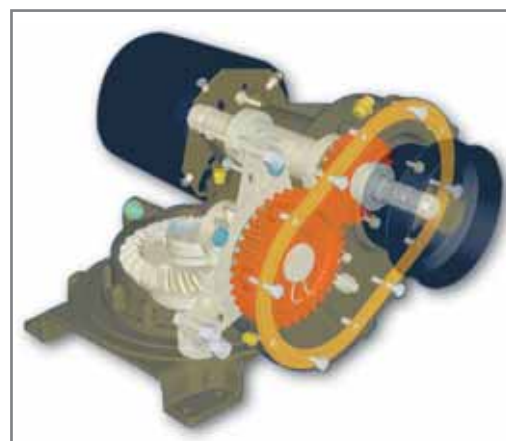

CAMBIO DI VELOCITÀ
Invertendo e sostituendo la coppia di ingranaggi è possibile disporre di numerosi rapporti di rotazione dei rotori.
Questo permette di ottimizzare il lavoro dell'erpice in funzione del tipo di terreno, della velocità di avanzamento e del grado di affinamento richiesto.

GEARBOX
By reversing the position of the changeable gears by replacing it, it is possible to have available several rotation ratios of the rotors. This makes it possible to obtain the best possible performance of the power harrow depending on the type of soil, on the forward speed and on the required degree of crumbling.

TRANSMISSION AVEC BOITE DE VITESSE
En inversant ou en changeant les pignons, vous disposez d'un nombre important de vitesses de rotation des rotors.
Cela permet une optimisation du travail de la herse rotative en fonction du type de terrain, de la vitesse d'avancement et de la qualité d'affinement que vous recherchez.

ERPICI ROTANTI FISSI E PIEGHEVOLI RIGID AND FOLDABLE POWER HARROWS HERSES ROTATIVES FIXES ET REPLIABLES



Tutti gli elementi delle trasmissioni sono progettati e costruiti in ALPEGO.

Dimensionamenti, scelta di materiali, trattamenti termici e sistemi di lubrificazione sono frutto di una lunga esperienza specifica e di numerosi test nelle condizioni più estreme.

All the transmission components are designed and built by ALPEGO.

Sizes, choice of materials, heat treatments and lubrication systems are the result of a very long specific experience and of a large number of tests performed under the most demanding conditions.

Tous les éléments de transmission sont conçus et construits chez ALPEGO.

Les dimensionnements, les choix des composants, les traitements thermiques et les systèmes de lubrification sont le fruit d'une longue expérience spécifique et d'innombrables tests dans les conditions les plus extrêmes.

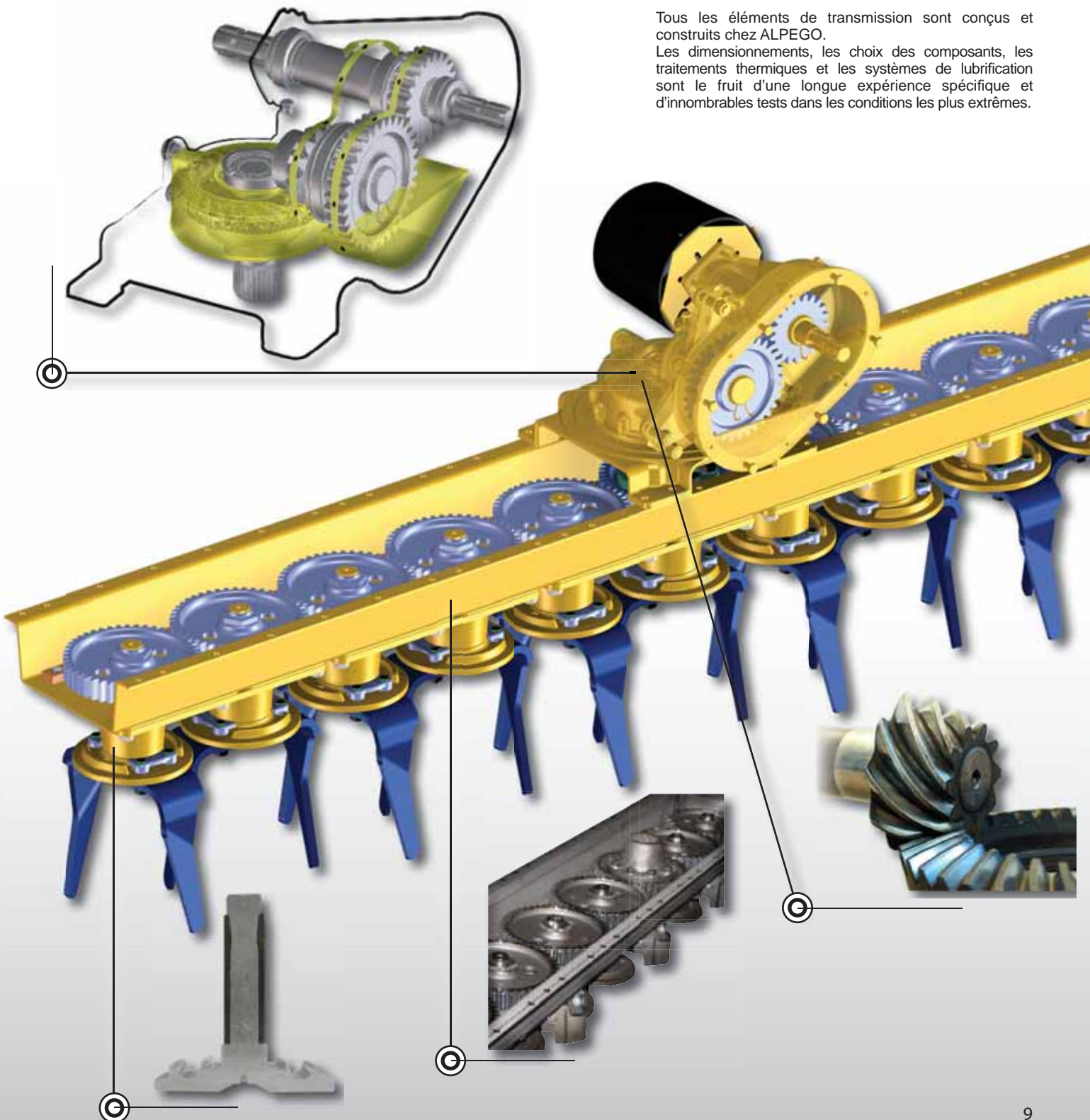

PIÙ CHE UN CONICO, È UN TWIN! *RATHER THAN A TAPERED ROLLER IT IS A TWIN!* PLUS QU' UN CONIQUE, C'EST UN TWIN!

(IT) Il sistema TWIN-FORCE consiste in 2 rotori montati su cuscinetti conici tenuti assieme da un unico supporto. Ciò permette l'allungamento dei denti e garantisce un'elevata affidabilità e maggior rendimento anche in abbinamento ad elevate potenze.

(GB) The TWIN-FORCE system consists of two rotors mounted on conical bearings, joined together by one support. This allows for longer tines and guarantees high reliability and an increased efficiency also in conjunction with high tractor powers.

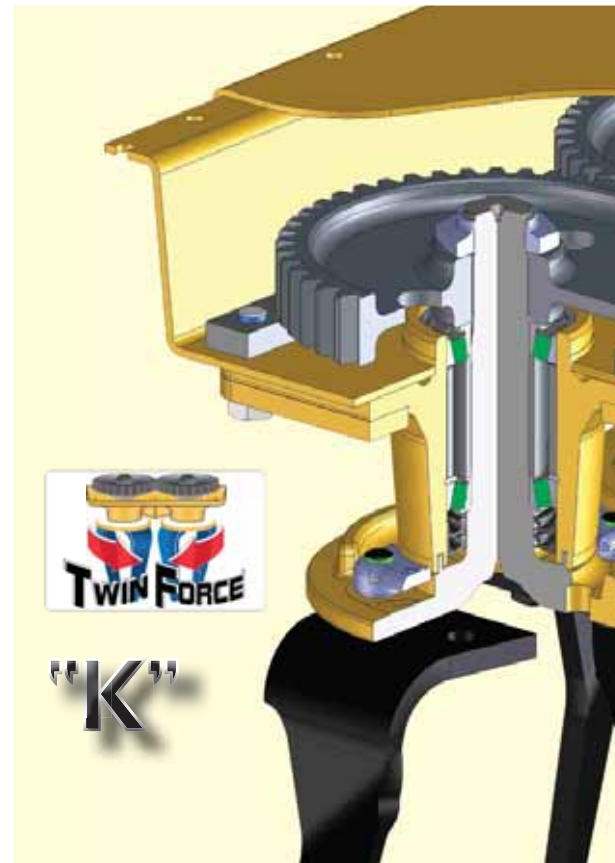
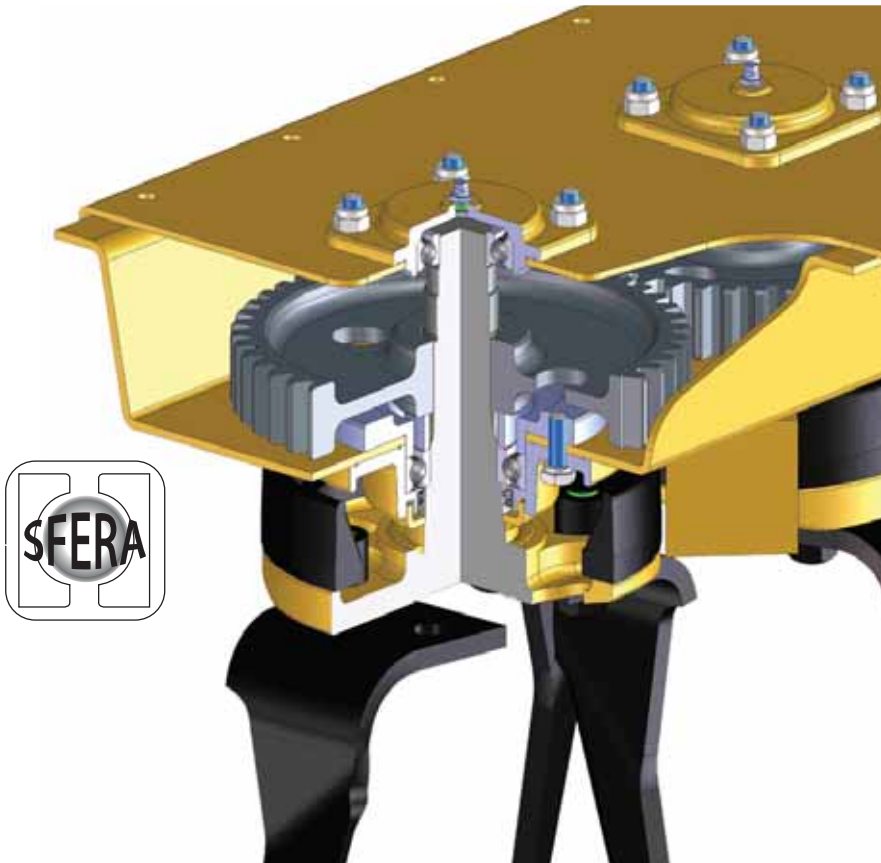

Erpice STANDARD
Cuscinetto a sfera

STANDARD Power harrow
Ball bearing

Herses STANDARD
Roulement à billes

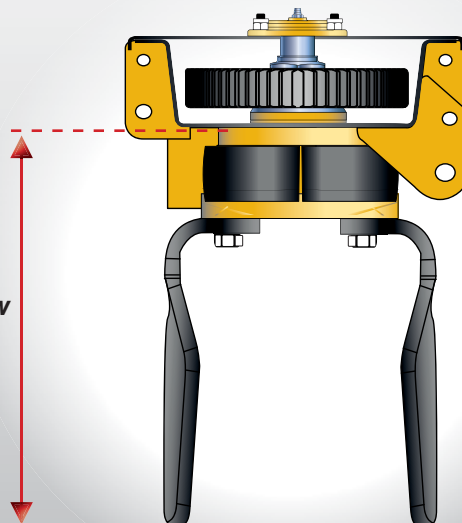

"Twin K"
Erpice STANDARD + 60 mm

"Twin K"
STANDARD Power harrow + 60 mm

"Twin K"
Herses STANDARD + 60 mm

ERPICI ROTANTI FISSI E PIEGHEVOLI
RIGID AND FOLDABLE POWER HARROWS
HERSES ROTATIVES FIXES ET REPLIABLES

(FR) Le système TWIN FORCE se compose de 2 rotors montés sur roulements coniques reliés par un seul support. Cela permet de rehausser la machine avec un grand dégagement qui garantit un rendement maximal et une fiabilité exceptionnelle sur des tracteurs de forte puissance.

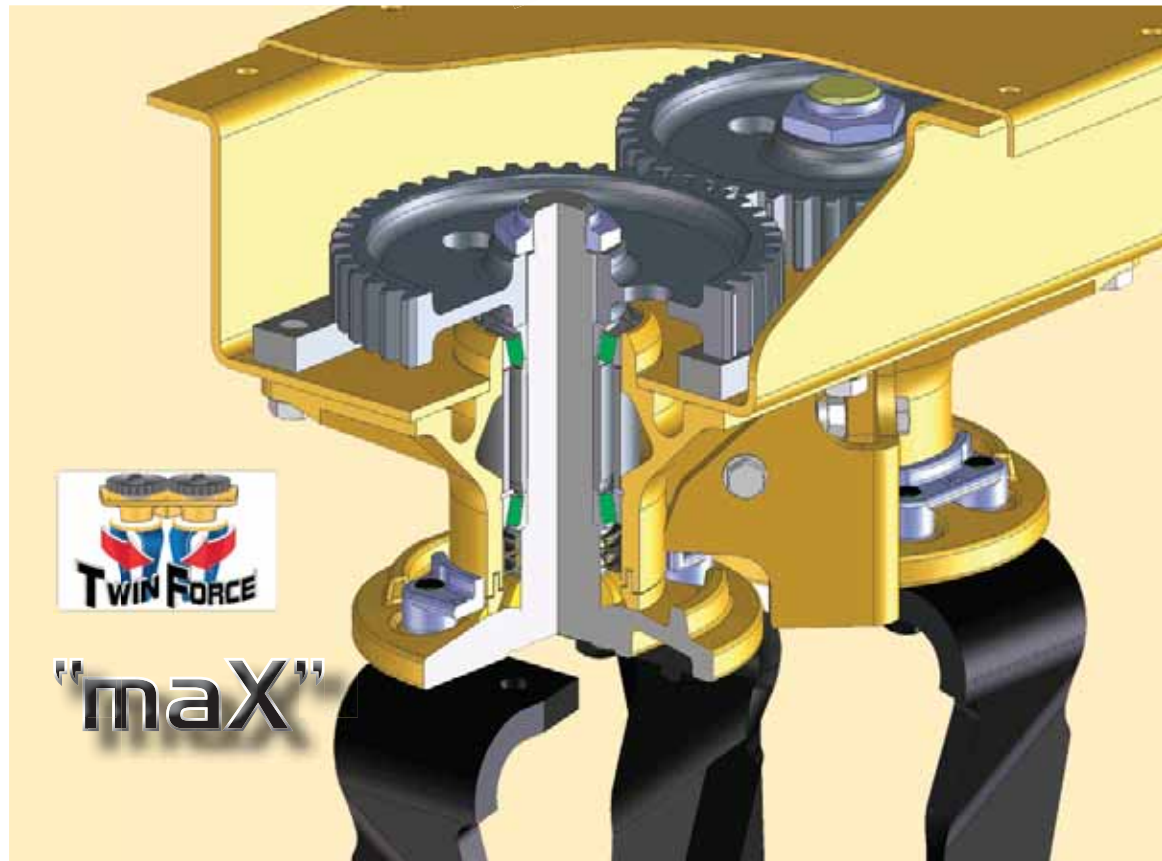
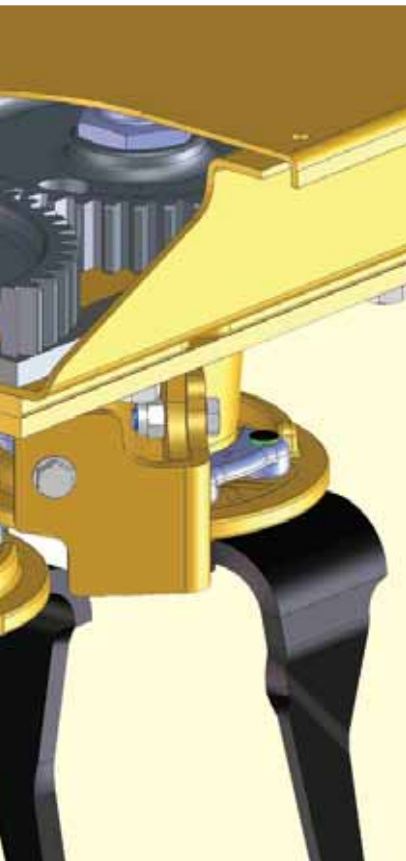

"maX"

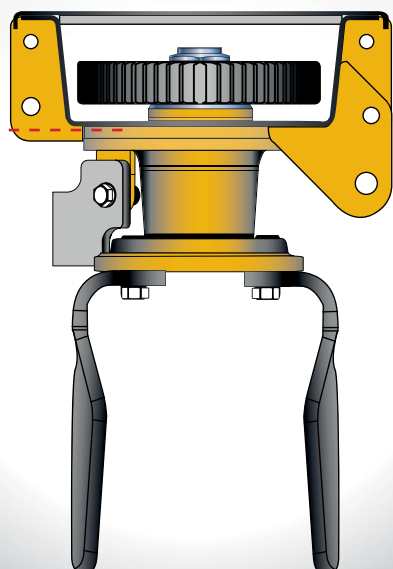

"Twin maX"
Erpice STANDARD + 100 mm

"Twin maX"
STANDARD Power harrow + 100 mm

"Twin maX"
Herses STANDARD + 100 mm

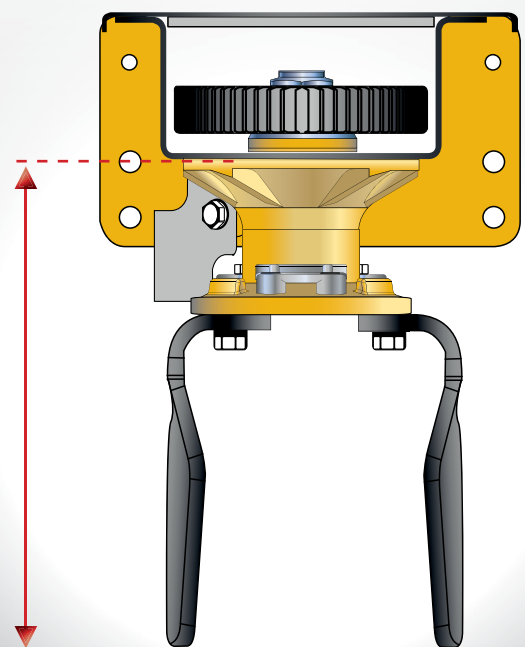



ACCESSORI OPTIONS ACCESSOIRES

Telaio oscillante / Floating frame / Châssis flottants

P.d.f. posteriore / Rear Pto / P.d.f arrière



- (1) Presa di forsa posteriore
- (1) Rear P.t.o.
- (1) P.d.f. arrière

- (1) Potenza massima trasmissibile 10 Kw
- (1) Pto maximum power 10 Kw
- (1) Puissance maximale transmissible 10 Kw

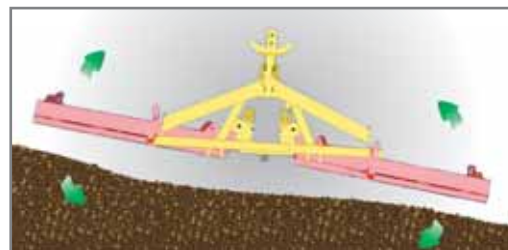
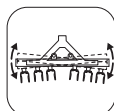

Negli erpici le 2 sezioni pieghevoli possono essere rese oscillanti, permettendo alla macchina di seguire le imperfezioni del terreno.

In the folding harrows the two folding halves can be made to float, thereby allowing the machine to adjust to the unevenness of the ground

Sur les herse, les 2 châssis latéraux repliables peuvent être réglés en position flottante, permettant à la machine de suivre parfaitement les oscillations du terrain.

Attacco seminatrice / Seed-drill carrier / Relevage hydraulique



Attacco idraulico per seminatrice su erpici fissi e pieghevoli

Hydraulic carrier for mounting a seed drill on rigid and on folding power harrows

Relevage hydraulique pour herse rotatives fixes et repliables

Rompitraccia / Track eraser / Effaces traces



Rompitraccia
Track eraser pair
Effaces traces



Rompitraccia NO-STOP
NO-STOP Track eraser pair
Effaces traces NON-STOP

ERPICI ROTANTI FISSI E PIEGHEVOLI RIGID AND FOLDABLE POWER HARROWS HERSES ROTATIVES FIXES ET REPLIABLES



Rulli / Roller / Rouleaux

RULLO GABBIA / CAGE ROLLER / ROULEAU BARRE



Il rullo GABBIA è adatto a terreni asciutti di media densità. Con dei kit aggiuntivi (optional solo per G5) è possibile infittire la trama di tubi e quindi aumentare la superficie d'appoggio. La struttura a gabbia non permette di sopportare carichi eccessivi come le combinate.

The CAGE roller is suitable for dry soils of medium density. With the extra kits (available only for the G5 series) it is possible to add some pipes to the cage, thereby increasing the supporting surface. The structure of the cage does not make it suitable to support very heavy loads, such as the combined implements

Le rouleau BARRE est adapté aux terrains sableux et légers. L'ajout du kit 8 tubes (en option sur G5) permet un meilleur rappui et une meilleure rotation du rouleau. La structure d'un rouleau barre ne permet pas de supporter des charges excessives telles que l'intégration d'un semoir en combiné.

G1	Ø 340
G4	Ø 420
G5N	Ø 500

Per / For / Pour:
RA - BD - BE - BF -
RM - RK - RmaX -
DJ - DP - DKS - DmaX

RULLO SPUNTONI / SPIKE ROLLER / ROULEAU POINTES



Il rullo SPUNTONI è molto versatile, lavora bene anche in condizioni di terreno umido e compatto. È utilizzabile per le combinazioni con seminatrice.

The SPIKE roller is very versatile, it works well even when the soil is damp and compacted. It can be used in the combinations with the seed drill

Le rouleau À POINTES est très polyvalent. Il permet un travail en conditions très humides et sur les sols collants. La combinaison avec un semoir est possible.

P1	Ø 400
P41	Ø 480
P5N	Ø 560

Per / For / Pour:
BD - BE - BF -
RM - RK - RmaX -
DJ - DP - DKS - DmaX

RULLO SPIRALE / SPIRAL ROLLER / ROULEAU SPIRALE



Il rullo SPIRAL permette di creare una superficie di semina soffice e compatta, va bene per terreni medi e leggeri. Non è utilizzabile per le combinazioni.

The SPIRAL roller creates a soft and uniform seeding surface and is suitable for medium and light soils.

Le rouleau SPIRALE permet de créer un lit de semence à la fois soufflé et porteur. Il convient bien aux terrains moyens et légers. Il ne peut pas être utilisé en combiné avec un semoir intégré.

SP1	Ø 380
SP3	Ø 450
SP5N	Ø 520

Per / For / Pour:
BD - BE - BF -
RM - RK - RmaX -
DJ - DP - DKS - DmaX

RULLO PACKER / PACKER ROLLER / ROULEAU PACKER



Il rullo PACKER ha una struttura tubolare di grande diametro, questo lo rende molto robusto e particolarmente adatto alle combinazioni con seminatrice. Diverse file di denti garantiscono la trazione col suolo e una serie di spatole registrabili singolarmente li mantiene puliti. Il risultato è una superficie compatta, perfetta per la semina.

The PACKER roller has a tubular structure with a large diameter: this makes it very sturdy and particularly suited for the combinations with seed drills. Several rows of tines guarantee the traction on the ground and a series of adjustable brushes keeps each of them clean. The result is a compact surface, perfect for sowing.

Le rouleau PACKER est doté d'une structure tubulaire de grand diamètre, ce qui le rend particulièrement bien adapté à la combinaison avec les semoirs intégrés. Son grand nombre de dents assure une rotation uniforme. Les grattoirs à la fois réglables individuellement et de manière centralisée permettent un parfait nettoyage. Il garantit une surface compacte parfaite pour le semis.

PK3	Ø 480
PK5N	Ø 520
PK6	Ø 570

Per / For / Pour:
BD - BE - BF -
RM - RK - RmaX -
DJ - DP - DKS - DmaX

RULLO GOMMA / RUBBER ROLLER / ROULEAU RAYONNEUR



Il rullo GOMMA è particolarmente indicato per le combinazioni con seminatrice da cereali: garantisce profondità costante del seme. La superficie in gomma di grande diametro riduce l'effetto incollante del terreno e agevola la trazione rendendolo un rullo adatto ad ogni condizione di lavoro.

The GOMMA (rubber) roller is suited for combinations with seed drills for cereals: it guarantees that the seed is placed at a constant depth. The rubber-covered surface and its large diameter decrease the clamping effect of the soil and makes it a roller suited for any work condition.

Le rouleau RAYONNEUR est idéal pour la combinaison avec un semoir à céréales: il garantit une régularité de profondeur de semis constante. Sa superficie en caoutchouc de grand diamètre réduit l'effet collant du terrain, favorisant ainsi sa rotation. Il est adapté à toutes les conditions de travail.

OT5N	Ø 500
------	-------

Per / For / Pour:
RK - RmaX -
DKS - DmaX

RULLO CRUMB / CRUMB ROLLER / ROULEAU CRUMB



Il rullo CRUMB è adatto per la lavorazione di terreni friabili, anche pesanti e umidi e permette un buono sminuzzamento e compattazione prima della semina.

The CRUMB roller is suitable for working friable soil, also heavy and wet, and allows a good crumbling and compaction before seeding. Scrapers avoid stopping.

Le rouleau CRUMB est adapté pour les travaux sur sols friables, mais aussi lourds et humides en offrant un bon émiettement et un rappui avant le semis.

CR3	Ø 480
-----	-------

Per / For / Pour:
BE - BF - RM -
DJ - DP

Erpice Fisso per trattori fino a 70HP
Rigid Power Harrow for tractors up to 70HP
Herses rotatives fixes pour tracteurs jusqu' à 70CV



IT CARATTERISTICHE

- Rotori portadenti circolari antingolfamento
- Denti a coltello a basso assorbimento di energia
- Ingombro laterale ridotto pari alla larghezza di lavoro
- Regolazione rapida del rullo
- Rullo flottante
- Cardano con limitatore a bullone att. trattore 1"3/8 Z=6
- Attacco al trattore di 1° e 2° cat.

GB FEATURES

- Rotors designed to avoid soil jamming
- Low power absorption tines
- Reduced overall dimensions equal to working width
- Roller with fast depth control
- Floating roller
- Universal joint with shear bolt 1"3/8 Z=6
- Linkage cat. 1 and 2

FR CARACTÉRISTIQUES

- Portes dents circulaire anti engorgement
- Dents à basse absorption d'énergie
- Largeur hors tout égale à la largeur de travail
- Réglage rapide de la profondeur de travail
- Rouleau flottant
- Cardan à sécurité boulon coté 1"3/8 Z=6 coté tracteur
- Chapes d'attelage de 1°, 2° catégorie

DATI TECNICI / TECHNICAL DATA / CARACTÉRISTIQUES TECHNIQUES

	HP	mm	mm	mm	(n°)	(n°)	KG	KG	KG	KG	KG
Rotodent RA-110	25-70	1100	1100	190	5	6dx+4sx	280	/	295	/	/
Rotodent RA-130	25-70	1300	1300	190	6	6+6	326	/	340	/	/
Rotodent RA-150	30-70	1500	1500	190	7	8dx+6sx	343	/	355	/	/
Rotodent RA-170	40-70	1700	1700	190	8	8+8	377	/	385	/	/
Rotodent RA-190	50-70	1900	1900	190	9	10dx+8sx	405	425	410	/	/
Rotodent RA-210	50-70	2100	2100	190	10	10+10	443	470	443	/	/
Rotodent RA-230	50-70	2300	2300	190	11	12dx+10sx	475	510	475	/	/

EQUIPAGGIAMENTO / EQUIPMENT / EQUIPEMENTS

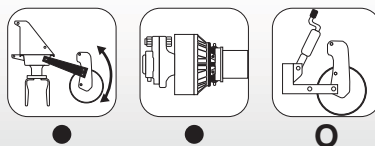

● = di serie - standard - de série ○ = Option - Optinal - Option / = Non disponibile - Not available - Non disponible

Erpice Fisso per trattori fino a 100HP
Rigid Power Harrow for tractors up to 100HP
Herses rotatives fixes pour tracteurs jusqu' à 100CV



IT CARATTERISTICHE

- Rotori portadenti circolari antingolfamento
- Denti a coltello a basso assorbimento di energia
- Protezioni contro i sassi sottovasca
- Ingombro laterale ridotto pari alla larghezza di lavoro
- Regolazione rapida del rullo
- Rullo flottante
- Cardano con limitatore a bullone att. trattore 1"3/8 Z=6
- Attacco al trattore oscillante di 2°cat.











GB FEATURES

- Rotors designed to avoid soil jamming
- Low power absorption tines
- Stone guards under the gear trough
- Reduced overall dimensions equal to working width
- Roller with fast depth control
- Floating roller
- Universal joint with shear bolt 1"3/8 Z=6
- Linkage cat.2, oscillating

FR CARACTÉRISTIQUES

- Portes dents circulaire anti engorgement
- Dents à basse absorption d'énergie
- Protection anti pierre sous le lamier
- Largeur hors tout égale à la largeur de travail
- Réglage rapide de la profondeur de travail
- Rouleau flottant
- Cardan à sécurité boulon coté 1"3/8 Z=6 coté tracteur
- Chapes d'attelage oscillantes de 2° catégorie

DATI TECNICI / TECHNICAL DATA / CARACTÉRISTIQUES TECHNIQUES

											
	HP	mm	mm	mm	(n°)	(n°)	KG	KG	KG	KG	KG
Rotodent BD-180	50-100	1800	1800	250	7	8dx+6sx	580	610	580	670	/
Rotodent BD-205	55-100	2050	2050	250	8	8+8	635	655	635	740	/
Rotodent BD-230	60-100	2300	2300	250	9	8dx+10sx	675	690	690	800	/

EQUIPAGGIAMENTO / EQUIPMENT / EQUIPEMENTS

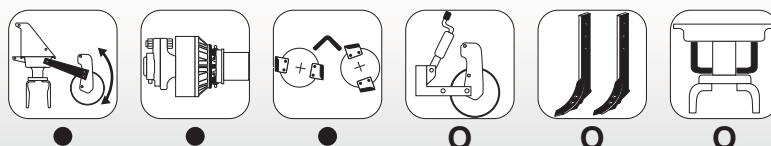

● = di serie - standard - de série ○ = Option - Optinal - Option / = Non disponibile - Not available - Non disponible

Erpice Fisso per trattori fino a 120HP
Rigid Power Harrow for tractors up to 120HP
Herses rotatives fixes pour tracteurs jusqu' à 120CV



IT CARATTERISTICHE

- Rotori portadenti circolari antingolfamento
- Denti a coltello a basso assorbimento di energia
- Protezioni contro i sassi sottovasca
- Ingombro laterale ridotto pari alla larghezza di lavoro
- Barra livellatrice fissata sul rullo con regolazione indipendente
- Regolazione rapida del rullo
- Rullo flottante
- Cardano con limitatore a bullone att. trattore 1"3/8 Z=6
- Attacco al trattore oscillante di 2°cat.

GB FEATURES

- Rotors designed to avoid soil jamming
- Low power absorption tines
- Stone guards under the gear trough
- Reduced overall dimensions equal to working width
- Levelling board on roller. Independently adjustable
- Roller with fast depth control
- Floating roller
- Universal joint with shear bolt 1"3/8 Z=6
- Linkage cat.2, oscillating

FR CARACTÉRISTIQUES

- Portes dents circulaire anti engorgement
- Dents à basse absorption d'énergie
- Protection anti pierre sous le lamier
- Largeur hors tout égale à la largeur de travail
- Barre niveleuse montée sur le rouleau à réglage indépendant
- Réglage rapide de la profondeur de travail
- Rouleau flottant
- Cardan à sécurité boulon coté 1"3/8 Z=6 coté tracteur
- Chapes d'attelage oscillantes de 2° catégorie

DATI TECNICI / TECHNICAL DATA / CARACTÉRISTIQUES TECHNIQUES

	HP	mm	mm	mm	(n°)	(n°)	KG	KG	KG	KG	KG
Rotodent BE-250	65-120	2500	2500	250	10	10+10	815	845	825	950	/
Rotodent BE-300	70-120	2980	3000	250	12	12+12	915	950	930	1080	/

EQUIPAGGIAMENTO / EQUIPMENT / EQUIPEMENTS

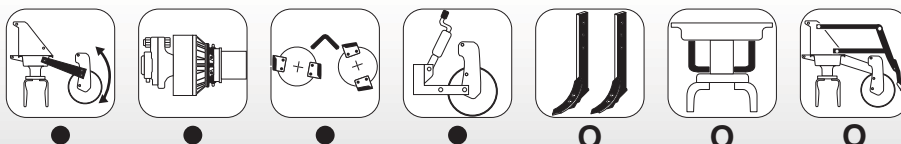

● = di serie - standard - de série ○ = Option - Optinal - Option / = Non disponibile - Not available - Non disponible

Erpice Fisso per trattori fino a 140HP
Rigid Power Harrow for tractors up to 140HP
Herses rotatives fixes pour tracteurs jusqu' à 140CV



IT CARATTERISTICHE

- Rotori portadenti circolari antingolfamento
- Denti a coltello a basso assorbimento di energia
- Protezioni contro i sassi sottovasca
- Ingombro laterale ridotto pari alla larghezza di lavoro
- Barra livellatrice fissata sul rullo con regolazione indipendente
- Regolazione rapida del rullo
- Rullo flottante
- Presa di forza in posizione centrale
- Cardano con limitatore a bullone att. trattore 1"3/8 Z=6
- Attacco al trattore oscillante di 2°cat.











GB FEATURES

- Rotors designed to avoid soil jamming
- Low power absorption tines
- Stone guards under the gear trough
- Reduced overall dimensions equal to working width
- Levelling board on roller. Independently adjustable
- Roller with fast depth control
- Floating roller
- Centrally positioned P.t.o.
- Universal joint with shear bolt 1"3/8 Z=6
- Linkage cat.2, oscillating

FR CARACTÉRISTIQUES

- Portes dents circulaire anti engorgement
- Dents à basse absorption d'énergie
- Protection anti pierre sous le lamier
- Largeur hors tout égale à la largeur de travail
- Barre niveleuse montée sur le rouleau à réglage indépendant
- Réglage rapide de la profondeur de travail
- Rouleau flottant
- Prise de force en position centrale
- Cardan à sécurité boulon coté 1"3/8 Z=6 coté tracteur
- Chapes d'attelage oscillantes de 2° catégorie

DATI TECNICI / TECHNICAL DATA / CARACTÉRISTIQUES TECHNIQUES

											
	HP	mm	mm	mm	(n°)	(n°)	KG	KG	KG	KG	KG
Rotodent BF-250	65-140	2500	2500	250	10	10+10	875	905	885	1010	/
Rotodent BF-300	75-140	2980	3000	250	12	12+12	965	1000	980	1130	/

EQUIPAGGIAMENTO / EQUIPMENT / EQUIPEMENTS

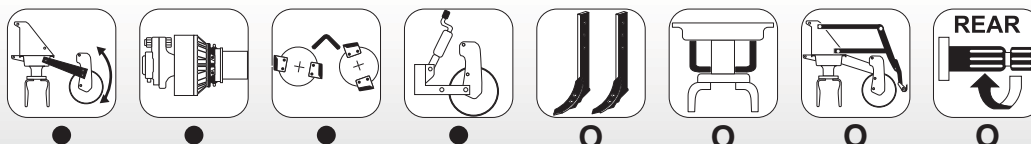

● = di serie - standard - de série ○ = Option - Optinal - Option / = Non disponibile - Not available - Non disponible

Erpice Fisso per trattori fino a 170HP
Rigid Power Harrow for tractors up to 170HP
Herses rotatives fixes pour tracteurs jusqu' à 170CV



IT CARATTERISTICHE

- Rotori portadenti circolari antingolfamento
- Denti a coltello a basso assorbimento di energia
- Protezioni contro i sassi sottovasca
- Ingombro laterale ridotto pari alla larghezza di lavoro
- Barra livellatrice fissata sul rullo con regolazione indipendente
- Regolazione rapida del rullo
- Rullo flottante montato su parallelogramma
- Presa di forza in posizione centrale
- Rotori su cuscinetti a rulli conici "TWIN-FORCE" serie "K"
- Attacco al trattore oscillante di 2°cat.

GB FEATURES

- Rotors designed to avoid soil jamming
- Low power absorption tines
- Stone guards under the gear trough
- Reduced overall dimensions equal to working width
- Levelling board on roller. Independently adjustable
- Roller with fast depth control
- Floating roller mounted on a parallelogram
- Centrally positioned P.t.o.
- Series "K" "TWIN-FORCE" with tapered roller bearings
- Linkage cat.2, oscillating

FR CARACTÉRISTIQUES

- Portes dents circulaire anti engorgement
- Dents à basse absorption d'énergie
- Protection anti pierre sous le lamier
- Largeur hors tout égale à la largeur de travail
- Barre niveleuse montée sur le rouleau à réglage indépendant
- Réglage rapide de la profondeur de travail
- Rouleau flottant monté sur parallélogramme
- Prise de force en position centrale
- Rotori montées sur roulements coniques à rouleaux "TWIN FORCE" série "K"
- Chapes d'attelage oscillantes de 2° catégorie

DATI TECNICI / TECHNICAL DATA / CARACTÉRISTIQUES TECHNIQUES

	HP	mm	mm	mm	(n°)	(n°)	KG	KG	KG	KG	KG
Rotodent RM-300	80-150	2980	3000	280	12	12+12	1265	1295	1310	1420	/
Rotodent RM-350 SUPER	90-170	3480	3500	280	14	14+14	1450	1495	1500	1640	/
Rotodent RM-400 SUPER	100-170	3980	4000	280	16	16+16	1600	1650	1640	1810	/

EQUIPAGGIAMENTO / EQUIPMENT / EQUIPEMENTS

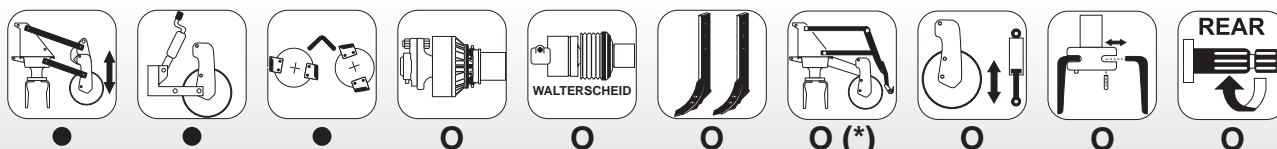

● = di serie - standard - de série ○ = Option - Optinal - Option / = Non disponibile - Not available - Non disponible
 (*)= utilizzabile solo con RM-300 / Only possible with RM-300 / Il est a utiliser seulement sur RM-300

Erpice Fisso per trattori fino a 200HP
Rigid Power Harrow for tractors up to 200HP
Herses rotatives fixes pour tracteurs jusqu' à 200CV



IT CARATTERISTICHE

- Rotori portadenti circolari antingolfamento
- Denti a coltello a basso assorbimento di energia
- Protezioni contro i sassi sottovasca
- Ingombro laterale ridotto pari alla larghezza di lavoro
- Barra livellatrice fissata sul rullo con regolazione indipendente
- Regolazione rapida del rullo
- Rullo flottante montato su parallelogramma
- Presa di forza in posizione centrale
- Rotori su cuscinetti a rulli conici "TWIN-FORCE" serie "K"
- Attacco al trattore oscillante di 2° e 3° cat. (RK-300 = 2° cat)

GB FEATURES

- Rotors designed to avoid soil jamming
- Low power absorption tines
- Stone guards under the gear trough
- Reduced overall dimensions equal to working width
- Levelling board on roller. Independently adjustable
- Roller with fast depth control
- Floating roller mounted on a parallelogram
- Centrally positioned P.t.o.
- Series "K" "TWIN-FORCE" with tapered roller bearings
- Linkage cat.2 and 3, oscillating (RK-300 = 2° cat.)

FR CARACTÉRISTIQUES

- Portes dents circulaire anti engorgement
- Dents à basse absorption d'énergie
- Protection anti pierre sous le lamier
- Largeur hors tout égale à la largeur de travail
- Barre niveleuse montée sur le rouleau à réglage indépendant
- Réglage rapide de la profondeur de travail
- Rouleau flottant monté sur parallélogramme
- Prise de force en position centrale
- Rotori montées sur roulements coniques à rouleaux "TWIN FORCE" série "K"
- Chapes d'attelage oscillantes de 2°, 3° catégorie (RK-300 = 2° catégorie)

DATI TECNICI / TECHNICAL DATA / CARACTÉRISTIQUES TECHNIQUES

	HP	mm	mm	mm	(n°)	(n°)	KG	KG	KG	KG	KG
Rotodent RK-300	90-200	2980	3000	280	12	12+12	1390	1420	1435	1645	1625
Rotodent RK-350	100-200	3480	3500	280	14	14+14	1570	1605	1610	1840	/
Rotodent RK-400	120-200	3980	4000	280	16	16+16	1750	1800	1775	2080	2068

EQUIPAGGIAMENTO / EQUIPMENT / EQUIPEMENTS

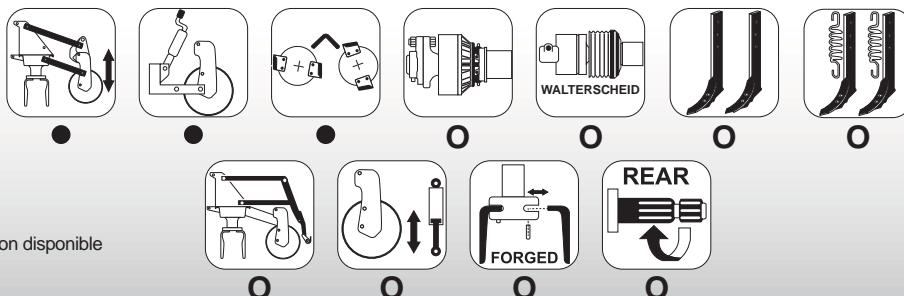

● = di serie - standard - de série
 ○ = Option - Optinal - Option
 / = Non disponibile - Not available - Non disponible

Erpice Fisso per trattori fino a 320HP
Rigid Power Harrow for tractors up to 320HP
Herses rotatives fixes pour tracteurs jusqu' á 320CV



IT CARATTERISTICHE

- Rotori portadenti circolari antingolfamento
- Portadenti a smontaggio rapido coltelli
- Protezioni contro i sassi sottovasca
- Barra livellatrice fissata sul rullo con regolazione indipendente
- Regolazione rapida del rullo
- Rullo flottante montato su parallelogramma
- Cardano con limitatore automatico att. trattore 1"3/8 Z=6
- Rotori su cuscinetti a rulli conici "TWIN-FORCE"
- Attacco al trattore oscillante di 3° cat.

GB FEATURES

- Rotors designed to avoid soil jamming
- Rotors for quick-fit tines
- Stone guards under the gear trough
- Levelling board on roller. Independently adjustable
- Roller with fast depth control
- Floating roller mounted on a parallelogram
- Universal joint Walterscheid with cam clutch 1"3/8 Z=6
- "TWIN-FORCE" with tapered roller bearings
- Linkage cat.3, oscillating

FR CARACTÉRISTIQUES

- Portes dents circulaire anti engorgement
- Portes dents à démontage rapide
- Protection anti pierre sous le lamier
- Barre niveleuse montée sur le rouleau à réglage indépendant
- Réglage rapide de la profondeur de travail
- Rouleau flottant monté sur parallélogramme
- Cardan à sécurité automatique à cames 1"3/8 Z=6 coté tracteur
- Rotori montées sur roulements coniques à rouleaux "TWIN FORCE"
- Chapes d'attelage oscillantes de 3° catégorie

DATI TECNICI / TECHNICAL DATA / CARACTÉRISTIQUES TECHNIQUES

	HP	mm	mm	mm	(n°)	(n°)	KG	KG	KG	KG	KG
Rotodent RmaX-300	120-320	2980	3000	300	12	12+12	1535	1565	1580	1790	1770
Rotodent RmaX-350	130-320	3450	3500	300	14	14+14	1750	1795	1800	2030	/
Rotodent RmaX-400	140-320	4000	4000	300	16	16+16	1940	1990	1965	2270	2258

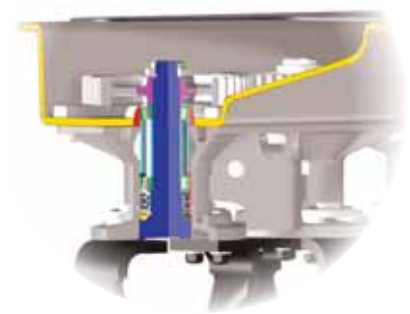
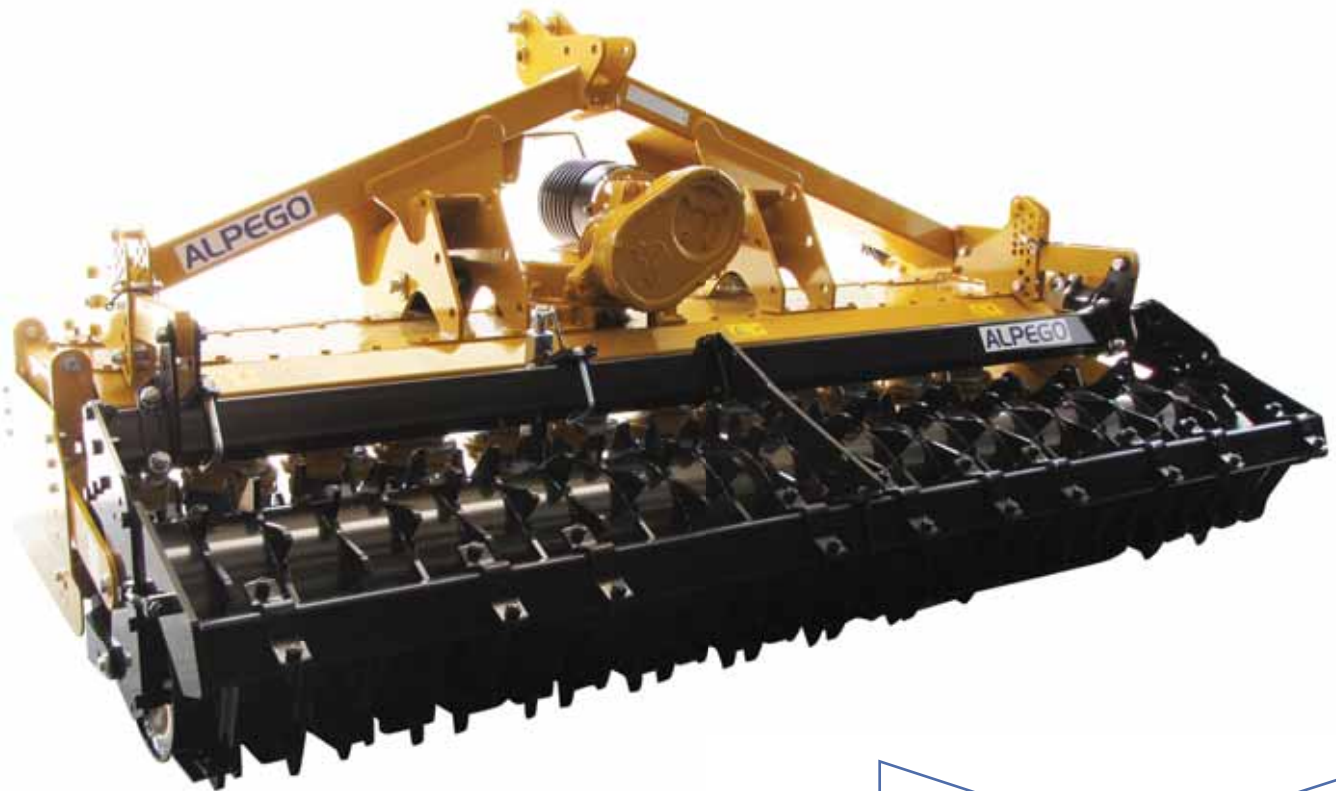

- Spessore vasca maggiorato;
- Meccanica maggiorata (cuscinetti, albero...)
- Thicker walls of trough;
- Sturdier mechanical parts (bearings, shaft...)
- Epaisseur du lamier majoré
- Mécanique renforcée (Roulements, arbres ...)

EQUIPAGGIAMENTO / EQUIPMENT / EQUIPEMENTS

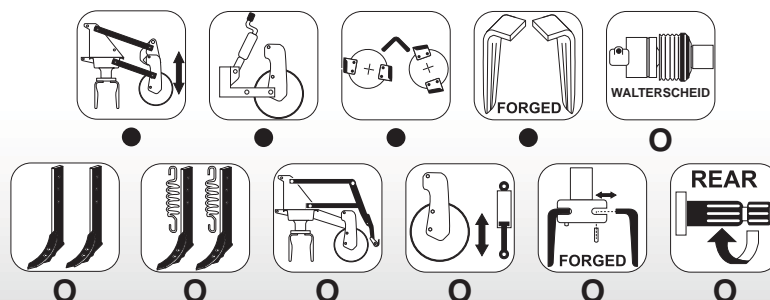

Erpice Pieghevole per trattori fino a 180HP
Foldable Power Harrow for tractors up to 180HP
Herses rotatives repliables pour tracteurs jusqu' à 180CV



IT CARATTERISTICHE

- Telaio portante monotrave con chiusura idraulica per un ridotto ingombro su strada (max 2.50m)
- Trasmissione a 3 invii
- Doppia sicurezza sulle trasmissioni laterali
- Sistema idraulico di sbloccaggio dei ganci di sicurezza
- Bloccaggi di sicurezza ad aggancio meccanico nella posizione chiusa
- Rotori portadenti circolari anti ingolfamento
- Denti a coltello a basso assorbimento di energia
- Protezione contro i sassi sottovasca
- Barra livellatrice fissata sul rullo con regolazione indipendente
- Regolazione rapida del rullo
- Rullo flottante
- Attacco al trattore oscillante di 2° e 3° cat.

GB FEATURES

- *Single-girder main frame with hydraulically controlled folding system for a reduced road transport width (max. 2.50 m.)*
- *3-gearbox transmission*
- *Double safety system on lateral gear boxes*
- *Hydraulic unlocking system*
- *Mechanic locking in folded position*
- *Rotors designed to avoid soil jamming*
- *Low power absorbing blade tines*
- *Stone guards under the gear trough*
- *Levelling board on roller. Independently adjustable*
- *Roller with fast depth control*
- *Floating roller*
- *Linkage cat.2 and 3, oscillating*

FR CARACTÉRISTIQUES

- Châssis porteurs mono poutre à repliage hydraulique pour une largeur au transport de 2.50m
- Transmission à 3 renvois
- Double sécurité sur chaque boîtier latéral
- Système hydraulique de déblocage des crochets de sécurité
- Blocage de sécurité à crochets mécanique en position fermée
- Portes dents circulaire anti engorgement
- Dents à basse absorption d'énergie
- Protection anti pierre sous le lamier
- Barre niveleuse montée sur le rouleau à réglage indépendant
- Réglage rapide de la profondeur de travail
- Rouleau flottant
- Chapes d'attelage oscillantes de 2°, 3° catégorie

Erpice Pieghevole per trattori fino a 220HP
Foldable Power Harrow for tractors up to 220HP
Herses rotatives repliables pour tracteurs jusqu' à 220CV



Nuova regolazione rapida del rullo
New quick adjustment system of the roller
Nouveau système de contrôle de profondeur

DATI TECNICI / TECHNICAL DATA / CARACTÉRISTIQUES TECHNIQUES

	HP	mm	mm	mm	(n°)	(n°)	KG	KG	KG	KG	KG
Rotodent DJ-360	90-180	3600	2500	250	14	14+14	1580	1640	1580	1760	/
Rotodent DJ-400	100-180	4000	2500	250	16	16+16	1736	1776	1736	1946	/
Rotodent DJ SUPER-460	110-220	4600	2500	250	18	18+18	1880	1920	1910	2130	/
Rotodent DJ SUPER-500	120-220	5000	2500	250	20	20+20	2000	2060	2020	2270	/

EQUIPAGGIAMENTO / EQUIPMENT / EQUIPEMENTS



DP

400

450

500

600

Erpice Pieghevole per trattori fino a 270HP
Foldable Power Harrow for tractors up to 270HP
Herses rotatives repliables pour tracteurs jusqu' á 270CV



IT CARATTERISTICHE

- Telaio portante con chiusura idraulica per un ridotto ingombro su strada (max 2.50m)
- Trasmissione a 3 invii con cambio
- Doppia sicurezza sulle trasmissioni laterali
- Bloccaggi di sicurezza ad aggancio meccanico nella posizione chiusa
- Rotori portadenti circolari anti ingolfamento
- Denti a coltello a basso assorbimento di energia
- Protezione contro i sassi sottovasca
- Barra livellatrice fissata sul rullo con regolazione indipendente
- Regolazione rapida del rullo
- Rullo flottante montato su parallelogramma
- Attacco al trattore oscillante di 2° e 3° cat.

GB FEATURES

- Heavy-duty folding frame for reduced overall width on road (max.2.50 m.)
- 3-gearbox transmission with speed selection
- Double safety system on lateral gear boxes
- Mechanic locking in folded position
- Rotors designed to avoid soil jamming
- Low power absorbing blade tines
- Stone guards under the gear trough
- Levelling board on roller. Independently adjustable
- Roller with fast depth control
- Floating roller mounted on a parallelogram
- Linkage cat.2 and 3, oscillating

FR CARACTÉRISTIQUES

- Châssis porteurs à repliage hydraulique pour une largeur au transport de 2.50m
- Transmission à 3 renvois avec boîte de vitesses
- Double sécurité sur chaque boîtier latéral
- Blocage de sécurité à crochets mécanique en position fermée
- Portes dents circulaire anti engorgement
- Dents à basse absorption d'énergie
- Protection anti pierre sous le lamier
- Barre niveleuse montée sur le rouleau à réglage indépendant
- Réglage rapide de la profondeur de travail
- Rouleau flottant monté sur parallélogramme
- Chapes d'attelage oscillantes de 2°, 3° catégorie



DATI TECNICI / TECHNICAL DATA / CARACTÉRISTIQUES TECHNIQUES

	HP	mm	mm	mm	(n°)	(n°)	KG	KG	KG	KG	KG
Rotodent DP-400	120-270	4000	2500	250	16	16+16	2240	2260	2280	2460	/
Rotodent DP-500	140-270	5000	2500	250	20	20+20	2480	2530	2560	2770	/
Rotodent DP-600	150-270	6000	2500	250	24	24+24	2740	2800	2830	3050	/

EQUIPAGGIAMENTO / EQUIPMENT / EQUIPEMENTS

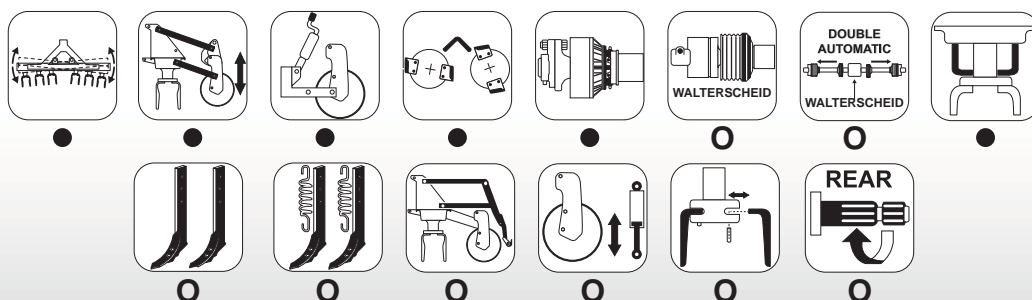

Erpice Pieghevole per trattori fino a 330HP
Foldable Power Harrow for tractors up to 330HP
Herses rotatives repliables pour tracteurs jusqu' á 330CV



Sistema idraulico di sbloccaggio dei ganci di sicurezza

Hydraulic unlocking system

Système hydraulique de déblocage des crochets de sécurité

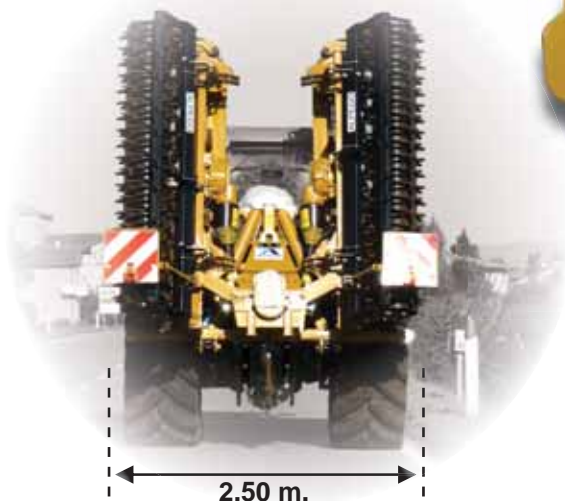

IT CARATTERISTICHE

- Telaio portante con chiusura idraulica per un ridotto ingombro di trasporto su strada (max.2.50 m)
- Trasmissione a 3 rinvii con cambio a 2 velocità centr.
- Doppia sicurezza sulle trasmissioni laterali
- **Sistema idraulico di sbloccaggio dei ganci di sicurezza**
- Rotori portadenti circolari antingolfamento
- Denti a coltello a basso assorbimento di energia
- Protezioni contro i sassi sottovasca
- Barra livellatrice fissata sul rullo con regolazione indipendente
- Regolazione rapida del rullo
- Rullo flottante montato su parallelogramma
- Rotori su cuscinetti a rulli conici "TWIN FORCE" system serie "K"
- Attacco al trattore oscillante di 3° cat.

GB FEATURES

- *Heavy-duty folding frame for reduced overall width on road (max.2.50 m.)*
- *3 gearboxes with a multiplespeed central gearbox*
- *Double safety system on lateral gearboxes*
- **Hydraulic unlocking system**
- *Rotors designed to avoid soil jamming*
- *Low power absorption tines*
- *Stone guards under the gear trough*
- *Levelling Board on roller. Independently adjustable*
- *Roller with fast depth control*
- *Floating roller mounted on parallelogram*
- *Series "K" "TWIN-FORCE" with tapered roller bearings*
- *Linkage cat.3, oscillating*

FR CARACTÉRISTIQUES

- Châssis porteurs à repliage hydraulique pour une largeur au transport de 2.50m
- Transmission a 3 renvois avec boite de vitesse a 2 vitesses centrals
- Double sécurité sur chaque boîtier latéral
- **Système hydraulique de déblocage des crochets de sécurité**
- Portes dents circulaire anti engorgement
- Dents à basse absorbion d'énergie
- Protection anti pierre sous le lamier
- Barre niveleuse montée sur le rouleau à réglage indépendant
- Réglage rapide de la profondeur de travail
- Rouleau flottant monté sur parallélogramme
- Rotori montées sur roulements coniques à rouleaux "TWIN FORCE" série "K"
- Chapes d'attelage oscillantes de 3° catégorie



DATI TECNICI / TECHNICAL DATA / CARACTÉRISTIQUES TECHNIQUES

	HP	mm	mm	mm	(n°)	(n°)	KG	KG	KG	KG	KG
Rotodent DKS-400	130-330	4000	2500	280	16	16+16	2520	2540	2560	2860	2830
Rotodent DKS-450	140-330	4500	2500	280	18	18+18	2630	2665	2690	3020	2985
Rotodent DKS-500	150-330	5000	2500	280	20	20+20	2810	2860	2890	3250	3210
Rotodent DKS-600	180-330	6000	2500	280	24	24+24	3100	3160	3190	3610	3570

EQUIPAGGIAMENTO / EQUIPMENT / EQUIPEMENTS

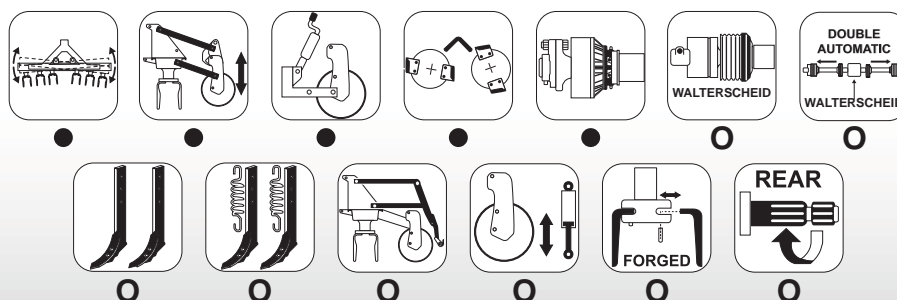

Erpice Pieghevole per trattori fino a 500HP
Foldable Power Harrow for tractors up to 500HP
Herses rotatives repliables pour tracteurs jusqu' à 500CV

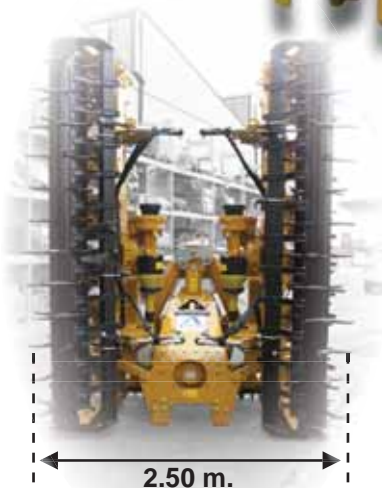

2.50 m.

IT CARATTERISTICHE

- Telaio portante con chiusura idraulica ingombro di trasporto su strada (max. 2.50 m.)
- Telaio con dispositivo automatico per posizione fissa o flottante
- Doppio cambio di velocità
- Trasmissioni laterali Walterscheid con dispositivo automatico di sicurezza "non stop"
- Serie cardani maggiorati per (DmaX-700 / DmaX-800)
- Protezioni speciali per i sassi
- Barra livellatrice fissata sul rullo con regolazione indipendente
- Regolazione rulli tramite parallelogramma
- Rotori su cuscinetti a rulli conici "TWIN FORCE" system serie "maX"
- Attacco al trattore oscillante di 3°, 4° cat. e 4° USA
- Nuove vasche spessore maggiorato

GB FEATURES

- *Heavy-duty folding frame, for reduced overall width on road (max.2.50 m.)*
- *Frame with automatic adjustment for fixed or floating position*
- *Multiplespeed central gearbox*
- *Double "no stop" safety system on lateral Walterscheid shafts*
- *Universal heavy-duty joints for (DmaX-700 / DmaX-800)*
- *Special stone-guards*
- *Levelling board on roller. Independently adjustable*
- *Roller on a parallelogram*
- *Rotor on tapered "TWIN FORCE" rollers, "maX" series*
- *Linkage cat.3, 4, and 4 USA oscillating*
- *New thicker troughs*

FR CARACTÉRISTIQUES

- Châssis porteurs à repliage hydraulique pour une largeur au transport de 2.50m
- Châssis avec dispositif automatique pour position fixe ou flottante
- Double changement de vitesse
- Transmissions latérales Walterscheid à sécurités automatiques à cames
- Série cardan renforcée pour (DmaX-700 / DmaX-800)
- Protection anti pierre sous le lamier
- Barre niveleuse montée sur le rouleau à réglage indépendant
- Réglage du rouleau par parallélogramme
- Rotor monté sur roulements coniques à rouleaux "TWIN FORCE" série "maX"
- Chapes d'attelage oscillantes de 3°, 4° catégorie et 4° USA
- Nouvelle vasque à épaisseur renforcée



DmaX

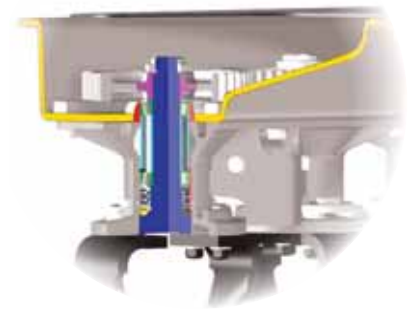

- Spessore vasca maggiorato;
- Meccanica maggiorata (cuscinetti, albero...)
- Thicker walls of trough;
- Sturdier mechanical parts (bearings, shaft...)
- Epaisseur du lamier majoré
- Mécanique renforcée (Roulements, arbres ...)

DATI TECNICI / TECHNICAL DATA / CARACTÉRISTIQUES TECHNIQUES

	HP	mm	mm	mm	(n°)	(n°)	KG	KG	KG	KG	KG
Rotodent DmaX-450	180-440	4500	2500	300	18	18+18	2780	2815	2840	3170	3135
Rotodent DmaX-500	180-440	5000	2500	300	20	20+20	3160	3210	3240	3600	3560
Rotodent DmaX-600	200-440	6000	2500	300	24	24+24	3480	3540	3570	3990	3950
Rotodent DmaX-700	250-500	7000	2500	300	28	28+28	/	/	/	4900	/
Rotodent DmaX-800	250-500	8000	2500	300	32	32+32	/	/	/	5330	/

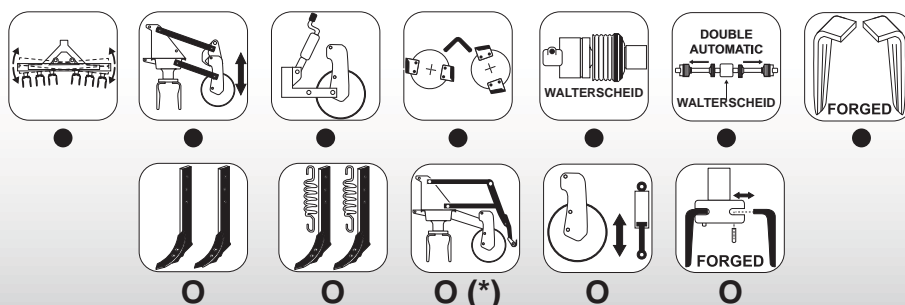

EQUIPAGGIAMENTO / EQUIPMENT / EQUIPEMENTS





● = di serie - standard - de série ○ = Option - Optinal - Option / = Non disponibile - Not available - Non disponible
 (*) = utilizzabile solo con DmaX 450/500/600 / Only possible with DmaX 450/500/600 / Il est a utiliser seulement sur DmaX 450/500/600

DATI TECNICI TECHNICAL DATE CARACTÉRISTIQUES TECHNIQUES

IT Condizioni di lavoro:



-  - terreni normali;
- utilizzo regolare;
(fino a 300 h/anno);
- combinazioni
-  - terreni difficili;
- utilizzo professionale con
frequenza lavoro elevata
e grandi estensioni;
- temperature ambientali
elevate

GB Working conditions:

-  - normal soils;
- regular use;
(up to 300 H/year);
- combinations
-  - difficult soils;
- professional use with
intense work frequency
and large-size farms;
- high environment
temperatures

FR

Conditions de travail :

-  - terrains normaux;
- utilisation régulière jusqu'à
300h/an;
- Montage en combiné
-  - terrenos difíciles
- uso profesional frecuentes
y/o grandes superficies
- temperatura ambiente
elevada

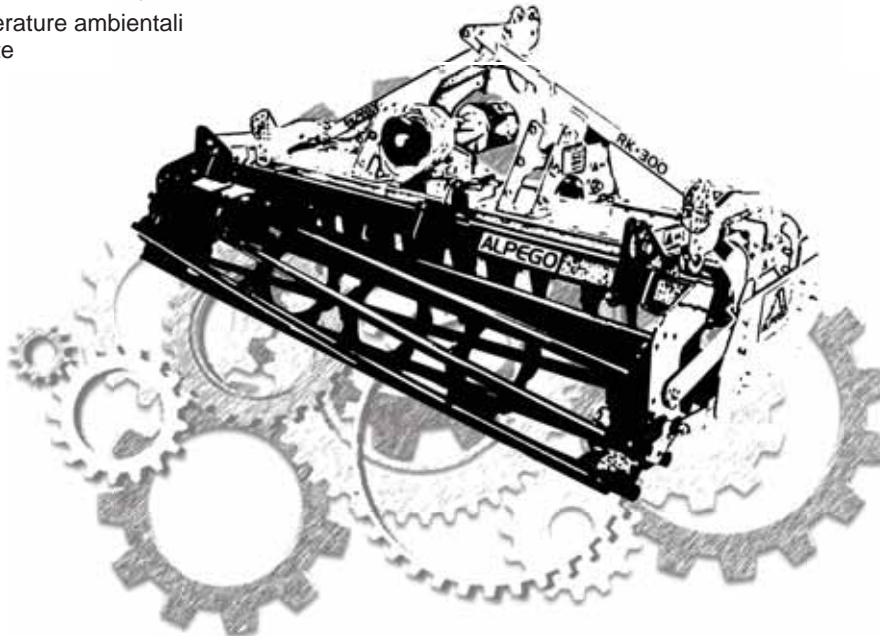

Giri ingresso P.d.F. / Ingoing r.p.m. of the P.t.o. / Régime prise de force		rpm	
Giri uscita rotori STD. / Outgoing r.p.m. to the STD. rotors / Vitesse de rotation des rotors std		rpm	
Giri uscita rotori in dotazione / Outgoing r.p.m. of the supplied rotors / Vitesses de rotation des rotors en option		rpm	
Spessore denti STD. / Thickness of STD. tines / Epaisseur des dents STD		mm	
Lunghezza denti STD. / Length of STD. tines / Longueur des dents STD		mm	
Rullo GABBIA / CAGE Roller / Rouleau BARRE			
Rullo SPUNTONI / SPIKE Roller / Rouleau À POINTES			
Rullo SPIRALE / SPIRAL Roller / Rouleau SPIRALE			
Rullo PACKER / PACKER Roller / Rouleau PACKER			
Rullo GOMMA / RUBBER Roller / Rouleau RAYONNEUR			
	Larghezza di lavoro cm (n° Rotori) / Working width in cm. (No. of rotors) / Largeur de travail cm (N° rotors) /		Larghezza di trasporto cm / Road transport width cm / Largeur de transport cm /
	110 (5)		
	130 (6)		
	150 (7)		
	170 (8)		
	180 (7)		
	190 (9)		
	205 (8)		
	210 (10)		
	230 (9)		
	230 (11)		
	250 (10)		
	300 (12)		
	350 (14)		
	360 (14)		
	400 (16)		
	450 (18)		
	460 (18)		
	500 (20)		
	600 (24)		
	700 (28)		
	800 (32)		

ERPICI ROTANTI FISSI E PIEGHEVOLI RIGID AND FOLDABLE POWER HARROWS HERSES ROTATIVES FIXES ET REPLIABLES

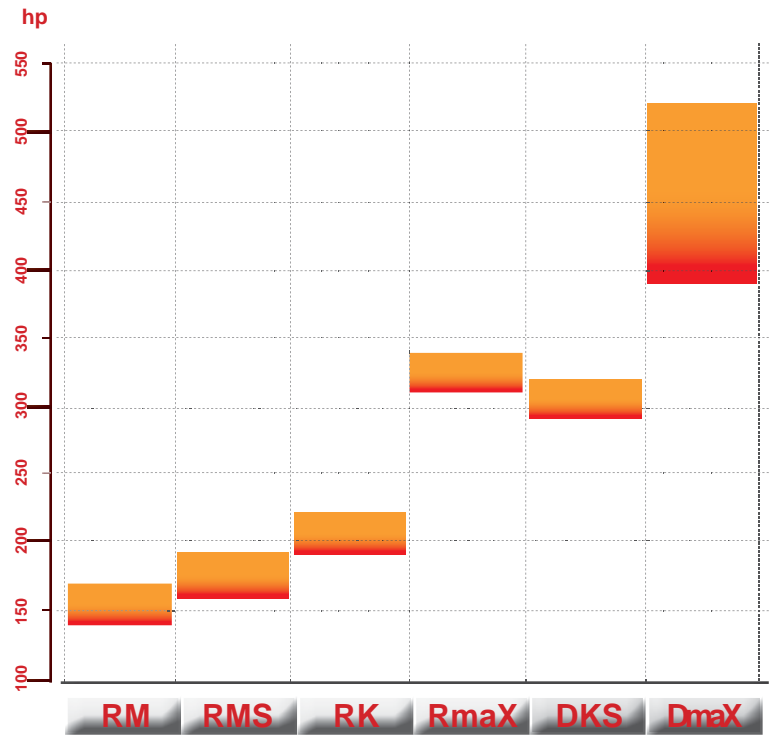
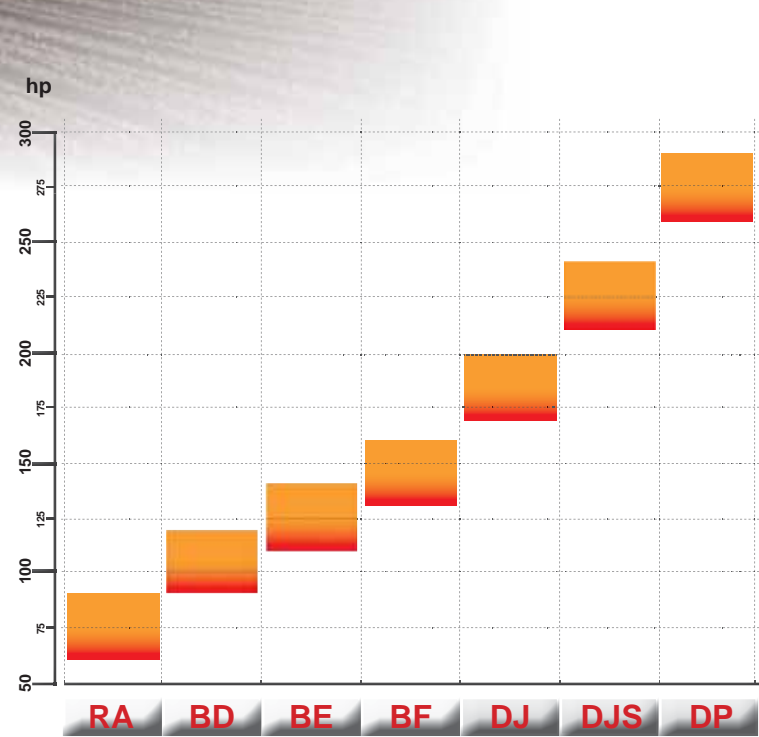

	RA	BD	BE	BF	RM	RK	RmaX	DJ	DJS	DP	DKS	DmaX
110 cm												
130 cm												
150 cm												
170 cm												
		180 cm										
190 cm		205 cm										
210 cm		230 cm										
230 cm			250 cm	250 cm								
			300 cm	300 cm	300 cm	300 cm	300 cm					
					350 cm	350 cm	350 cm					
					400 cm	400 cm	400 cm	250 cm				
								250 cm		250 cm	250 cm	250 cm
									250 cm	250 cm	250 cm	250 cm
										250 cm	250 cm	250 cm
											250 cm	250 cm
												250 cm
												250 cm
540	540	540	540	540	1000	1000	1000	1000	1000	1000	1000	1000
260	300	300	340	270	336	343	368	350	350	328	359	368
							273					396
12	12	12	12	14	14	14 (RAPIDO 17)	18 (RAPIDO 17)	12	12	12	14 (RAPIDO 17)	18 (RAPIDO 17)
300	300	300	300	300	300	300 (RAPIDO 320)	310 (RAPIDO 320)	300	300	300	300 (RAPIDO 320)	310 (RAPIDO 320)
G1	G4	G4	G4	G4	G4÷G5N	G5N	G5N	G4	G4	G4÷G5N	G5N	G5N
P1	P41	P41	P41	P41	P41÷P5N	P5N	P5N	P41	P41	P41÷P5N	P5N	P5N
SP1	SP3	SP3	SP2	SP3	SP3÷SP5N	SP5N	SP5N	SP3	SP3	SP3÷SP5N	SP5N	SP5N
-	PK3	PK3	PK3	PK3	PK3÷PK5N	PK5N÷PK6N	PK5N÷PK6N	PK3	PK3	PK3÷PK5N	PK5N÷PK6N	PK5N÷PK6N
-	-	-	-	-	-	OT5N	OT5N	-	-	-	OT5N	OT5N

COLTIVATORI

Cultivators / Déchaumeurs

3.00 - 5.00 mt
120 - 320 HP



PREPARATORE A DISCHI

Disc cultivator / Déchaumeurs à disques

2.50 - 8.00 mt
80 - 400 HP



RIPUNTATORI

Subsoilers / Décompacteurs

1.60 - 5.00 mt
80 - 500 HP



FRESATRICI

Rotary cultivators / Fraises rotatives

1.60 - 4.00 mt
50 - 240 HP



SEMINATRICI

Seed-drills / Semoirs

2.50 - 8.00 mt
80 - 500 HP



TRINCIATRICI

Flail mowers / Broyeurs

1.10 - 3.20 mt
40 - 160 HP



Immagini e dati inseriti nel presente catalogo non sono impegnativi e possono essere modificati in ogni momento senza obbligo di preavviso.
Images and texts here represented cannot be considered binding and can be modified at manufacturer's discretion.
Les images et données techniques contenues dans ce catalogue ne sont pas contractuelles. Nous réservons de droit de modifier à tout moment nos machines et leurs accessoires.

O10A00182/5 - DEPLIANT "GAMMA Epioci rotanti"
IT-GB-FR 21/11/2016



Alpego S.p.a

Via Giovanni e Giuseppe Cenzato, 9
36045 Lonigo (VI) Italy
Tel. +39 0444646100
Fax: +39 0444646199
www.alpego.com
info@alpego.com